

# RIDER

## A PIECE OF BREAD

### DESCRIPTION

Visual theatre for early childhood and medium format

Recommended age from 3 years old

Duration: 40 minuts

Public italiana, maximum 150-200 people

Minimum required surface area 4x3m

Space that can be darkened

Preferably in a non-elevating setting



### LIGHTING

Lighting plan at the end of the form. The venue must provide the minimum equipment required by the company. The company is responsible for adapting and implementing the necessary equipment for each venue. If the minimum equipment is not available, this will be negotiated with the company.

### SOUND

The theater will provide its PA system, a monitor, and enough cabling to connect a soundboard brought by the company to the theater's system.



CIA. LES PINYES

## **MACHINERY**

The theatre will provide a space where you can hang a rope at the back of the stage. Whether it's a wall, tripods, or any other alternative.

## **ATREZZO**

-

## **ASSEMBLY DETAILS**

The show takes place on the day of the performance. Arrive at the theatre at least **3 hours** before the performance.

Transportation is provided by large car or small van.

**SETUP: 3 hours**

**TIME TO PREPARE THE NEXT SHOW: 40 minutes**

**TEARDOWN: 60 minutes**

## **PRODUCTION NEEDS**

**1 vacuum cleaner**

**2 brooms and dustpans**

**IMPORTANT: This is a show that uses flour**

## **THEATRE STAFF**

**1 person in charge of sound**

**1 person in charge of lighting**

**1 person in charge of machinery**

## **OTHER NEEDS**

**Dressing room and water**

**Show adaptable to all types of spaces and resources**



**CIA. LES PINYES**

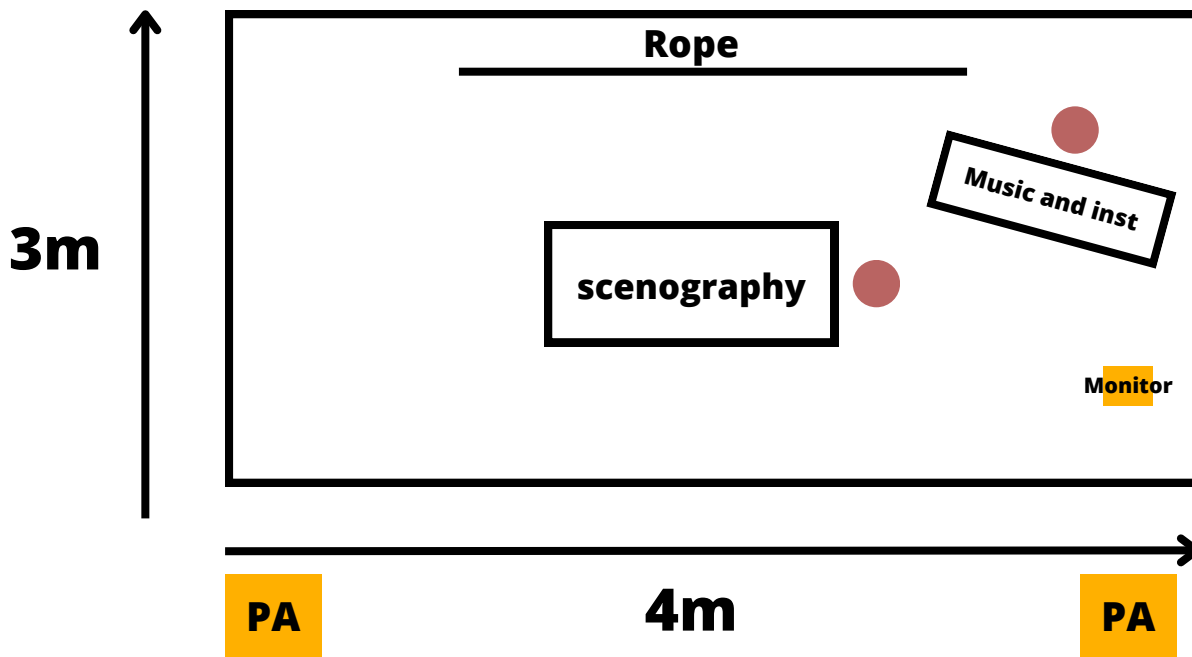

## PUBLIC

● 2 direct current points

### PRODUCTION CONTACT

Judit M. Gene · +34 617054435

[pinyabausch@gmail.com](mailto:pinyabausch@gmail.com)

To obtain the contact information for the technical manager, first contact production, and they will direct you to the appropriate contact.





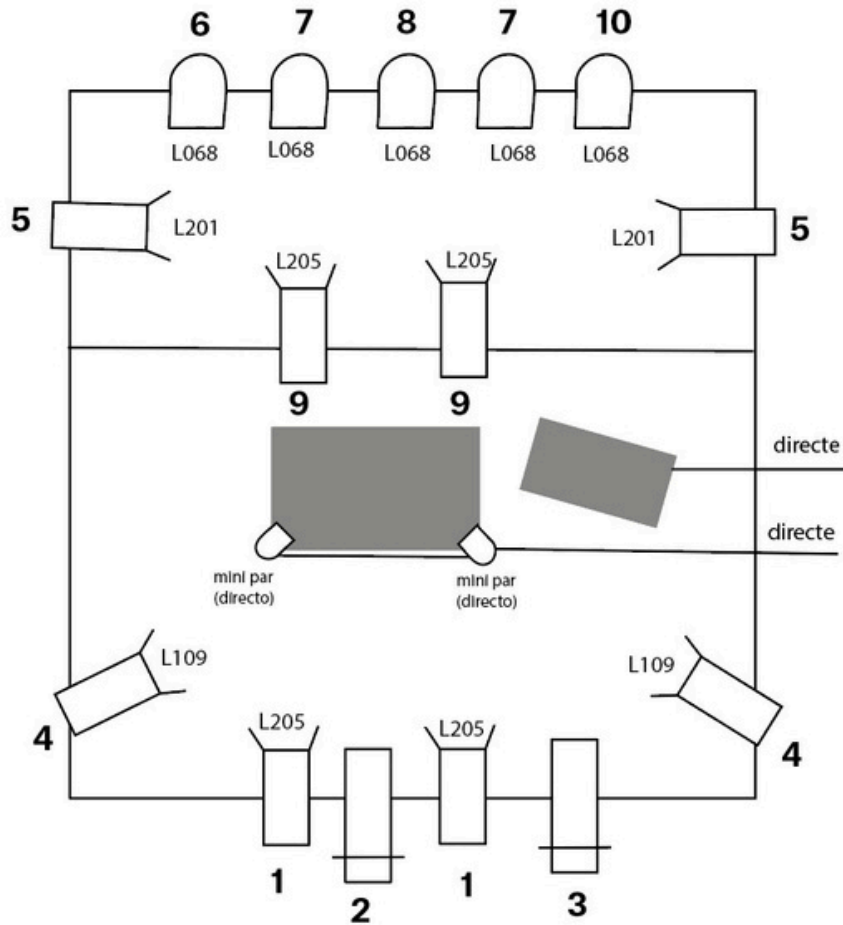

CIA. LES PINYES

# Ideal for the company

CIA. LES PINYES  
'UN TROS DE PA'



	<b>PC (x8)</b>
	<b>PAR n°5 (x5)</b>
	<b>RECORTE (x2)</b>
	<b>MINI PAR (directo)</b>

# Minimum

